

EMD 1000 H.P., DIESEL, SW1000

LOCO NO. 459

PAGE B-4

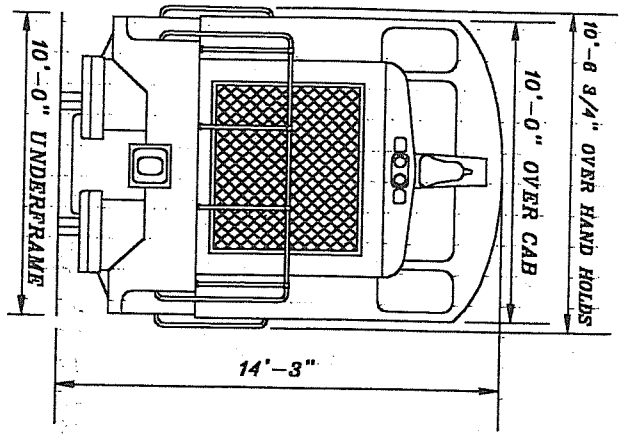
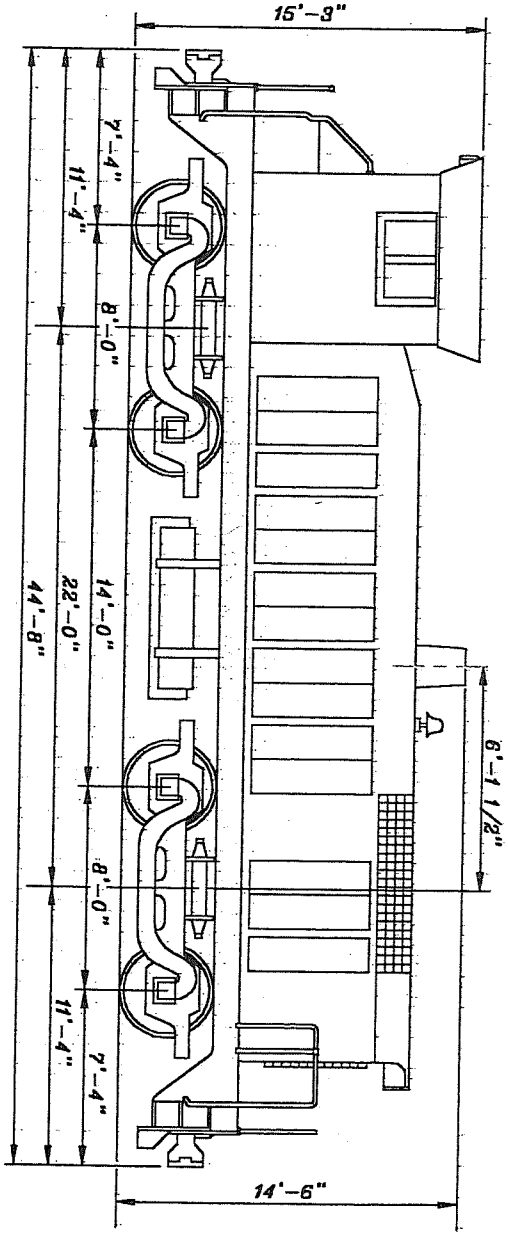

- WIDTH OVER HOOD 7'-0"
- 6 1/2" x 12" ROLLER BEARING TRUCKS
- EXTREME WIDTH 10'-6 3/4"
- EXTREME HEIGHT 15'-3"

APPROVED:

E. J. & E. RY. CO.
JOLIET, ILL.

EMD 1000 H.P., DIESEL, SW1000
LOCO NO. 459

DRAWN BY R.D.K. 1-27-89

REV.	9-89	4-95	3-01			SHEET NO. 14219
------	------	------	------	--	--	-----------------

★ SOLD TO DELRAY *BRN*

Locomotive Series - 459

Equipment	Engines	Data
Air Comp.: WBO, 3 Cylinder	Block: B-645-E	Gear Ratio: 62:15
Water-cooled	Power Assy: 645-E	Max. Speed: 65 MPH
Brake Schedule: 26NE 26L (5706)	Rating: 1000 HP	Avg Lt. Weight: 229,700#
Aux. Generator: 10KW	Air Filters: A.A.F. Size 1200 Bag	Max. Trac. Effort: 57,500#
Multiple Unit Controls: No	Speed - Idle: 315 RPM	Min. Curve Radius: 70'-0"/90°
Braking Equip.: Dual Clasp	Speed - Full: 900 RPM	
Brake w/Cast Iron Shoe		Capacities
Wheels: 40" Diameter		Lube Oil: 135 Gal.
Main Generator: D-32-E1		Fuel: 600 Gal.
Sanding Equip.: Electro-Pneumatic		Water: 190 Gal.
Transition: None		Sand: 30 Cu. Ft.

Locomotive 459 was built in 1971, and acquired from Gibbs Railway Supply in 1989, AFE #2870 (Formerly New Orleans Public Belt #101).

Unit equipped with cellular phone and fax machine in 1992. - ~~REMOVED~~